

MOST POWERFUL. VERSATILE. EFFICIENT.

GRIZZLY M550e – A FORESTRY MULCHER FOR THE MOST POWERFUL EXCAVATORS

The new Grizzly M550e with a working width of 1,300 mm (51 in) is a forestry mulcher for the large excavators from 21–32 t.

It is equipped with a powerful 107 cc or 170 cc hydraulic motor to cover the flow range of the excavators in this range and to ensure the best performance for perfect mulching results.

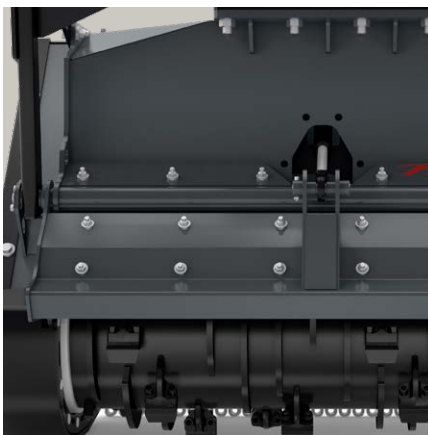
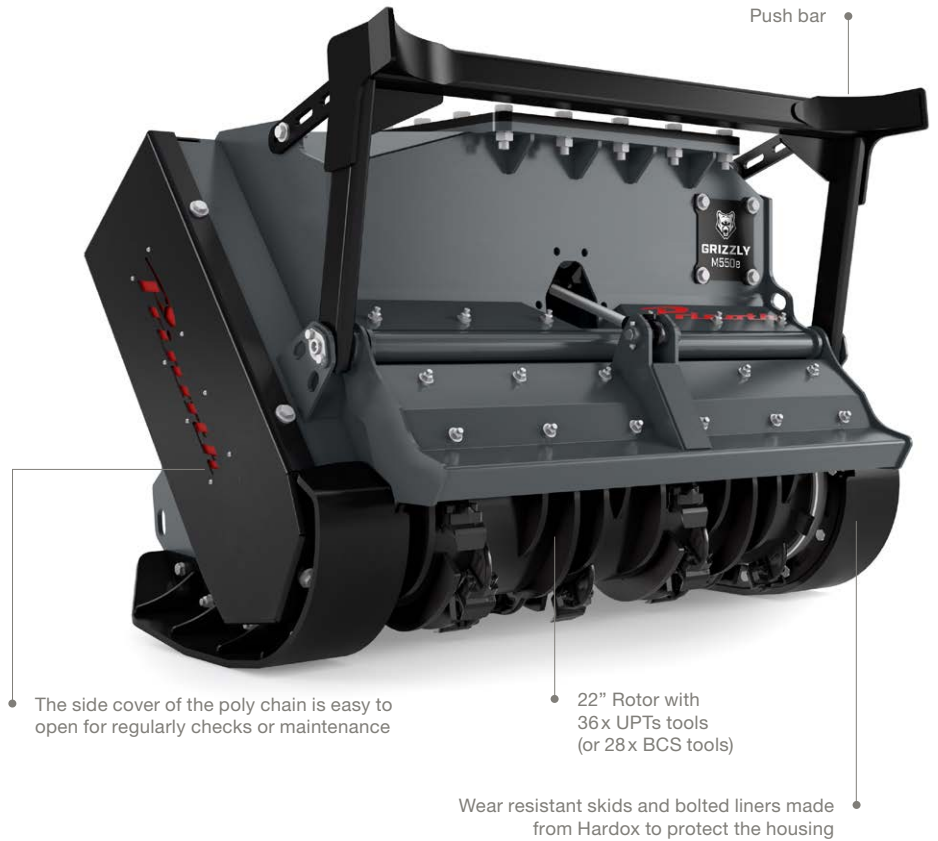

HOUSING

The housing is covered with bolted liners with counter blades which protect the housing and ensure additional shredding of the material while passing the housing.



PROTECTION FLAP

The optional flap is equipped with counter blades for additional shredding and perfect mulching results. It provides additional safety while mulching next to roads or in residential zones.



MAINTENANCE

Service points for greasing as well as to the hydraulic motor of the M550e-1300 are accessible easily. All greasing points can be reached from the outside without additional tools.

Pinoth[®]

POWERFUL AND VERSATILE

The modified Grizzly M550e mulcher offers new technical features to meet market and customer requirements. The concept makes it universally applicable for mulching of trees and brush.

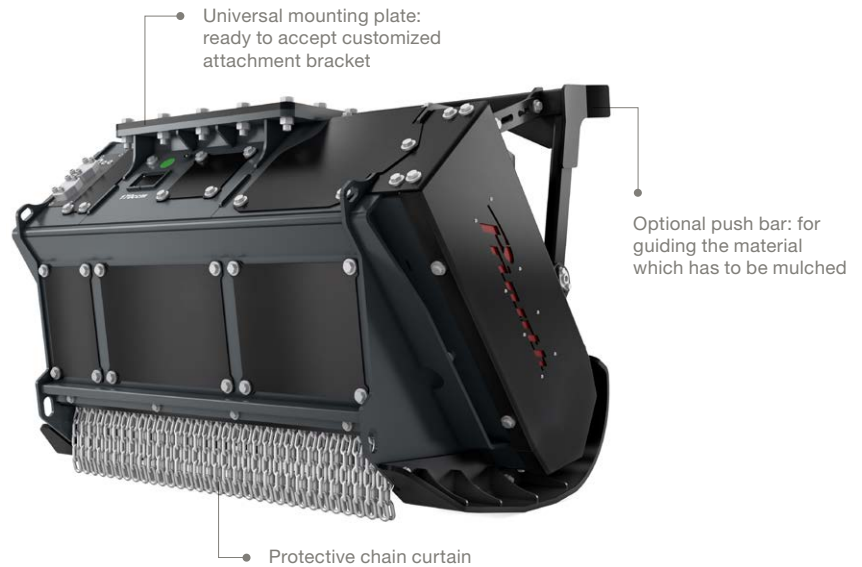

MAIN TECHNICAL BENEFITS

- Powerful and high efficiency 107 cc or 170 cc HD variable displacement motors
- NEW: Power transfer with new poly chain system prevents slippage and reduces maintenance
- NEW: Flexible configuration with optional flap – hydraulically or electronically controlled
- Hydraulic connections protected inside the housing
- Robust design of the push bar for optimum mulching result

TECHNICAL DATA GRIZZLY M550e

Working width	51.2 in (1,300 mm)
Total width	66.1 in (1,680 mm)
Weight*	3,417 – 3,748 lbs (1,550 – 1,700 kg)*
Rotor diameter	21.7 in (550 mm)
Volume flow	107 cc: 39.6 – 50.2 gpm (150 – 190 l/min) 170 cc: 44.9 – 79.3 gpm (170 – 300 l/min)
Tools	28 x BCS or 36 x UPTs
Height (without push bar)	45.0 in (1,141 mm)
Height (with push bar)	48.7 in (1,236 mm)
Depth (without flap)	41.5 in (1,054 mm)
Depth (with flap / with push bar)	47.8 in (1,215 mm)

*Weight depending on the configuration of the machine

Prinoth GmbH
 Im Branden 15
 88634 Herdwangen
 GERMANY
 Phone +49 7557 92120
prinoth.germany@prinoth.com

Prinoth AG
 Brennerstraße 34
 39049 Sterzing
 ITALY
 Phone +39 0472 72 26 22
prinoth@prinoth.com

Locate your nearest sales and service points at [prinoth.com](https://www.prinoth.com)

© 2024. Technical specifications depend on equipment and may vary. Illustrations may contain optional features that do not come as standard. Prinoth reserves the right to make changes and updates at any time without prior notice. Version 07/2024

Prinoth[®]