



JARRAFF

By *Pinotti*



Self-leveling chassis, articulated steering, and wheels retractable from 10' to 42"; equals access to tight spaces and slope stability without outriggers.

J MINI-JARRAFF URBAN TREE TRIMMER

SAFER

Operator runs machine remotely and out of harm's way; with better visibility. Safety features like LED lights, fire extinguishers, and dielectric tested boom.

EASIER FASTER

Reduces trimming work to a one-person, one-machine job. Quickly and easily trailered and towed behind a ¾ ton pickup for maximum on-the-job time.

Performs many times the work daily than conventional methods like bucket trucks, lifts, and climbers. Most advanced, automated method for trimming available.

Fifty-five foot reach, 360-degree boom rotation, and 180-degree saw blade rotation enables unparalleled access for precision cutting to ANSI standards.

ACCURATE

PROFITABLE

Exceptional longevity and hours of use, low down time, ease of service, and low total cost of ownership. Forty-year reputation for parts and service response.

Ideal for trimming urban landscapes and residential neighborhoods. Sold direct to utilities, government, and contractors. Fully manufactured in the U.S. by woman owned Jarraff Industries.

FOR THE SMARTER WAY TO TRIM TREES

THE MINI-JARRAFF URBAN TREE TRIMMER

Manufactured in the USA, the Mini-Jarraff Urban Tree Trimmer is designed for Right-of-Way maintenance and tree trimming operations in neighborhoods and other municipal settings. The Mini-Jarraff is simply the smartest way to trim trees. Contact Jarraff Industries today.



SHE'S PASSIONATE About Tree Care,
But Would Rather do
Her Climbing on a Rock Wall





LINEBACKER® **Brush Cutter**

Designed for land clearing, ROW maintenance, storm clean-up, and fire control.



JARRAFF® **All-Terrain Tree Trimmer**

Designed for heavy-duty Right-of-Way maintenance and trimming.



MINI-JARRAFF® **Urban Tree Trimmer**

Ideal for trimming urban landscapes and residential neighborhoods.



JARRAFF

By *Pinotti*

JARRAFF.COM | 800-767-7112

Jarraff Industries LLC
1731 Gault Street
St. Peter, MN 56082

Mini-Jarraff FEATURES

The Mini-Jarraff's **MAINTENANCE-FREE BOOM BELT DRIVE SYSTEM** offers quiet operation, reduces downtime and requires only a periodic adjustment.

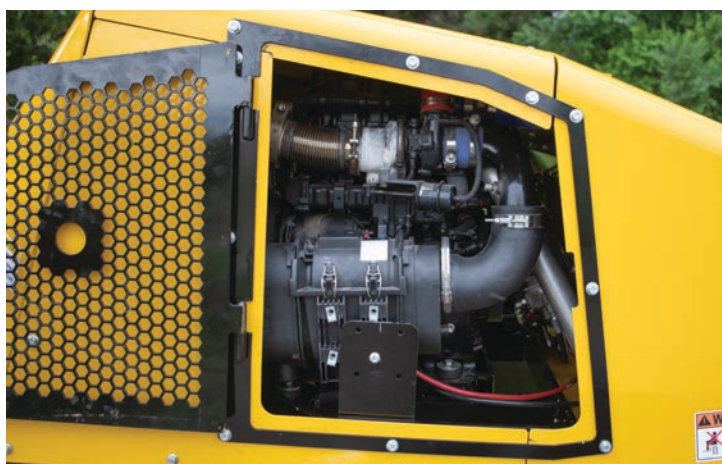

EPA compliant **74HP TIER4 DEUTZ DIESEL ENGINE** delivering increased power and performance more efficiently. Engine on demand ECO mode allows for even better fuel efficiency than ever before. No DEF required.



The Mini-Jarraff can easily navigate through difficult rural areas or urban locations. A **SELF-LEVELING CARRIER** allows the Mini-Jarraff to travel effectively on all types of terrain. Automatically adjusting legs narrow the machine's overall width to 48" and widen to 126" allowing the machine to work in the tightest of spaces, no outriggers required.

Mini-Jarraff FEATURES

Easy to use, ergonomically designed, **WIRELESS OPERATOR REMOTE CONTROL** with extended range allows the user to maintain a safe distance from machine during operation. **SCS (SAFEGUARD CONTROL SYSTEM)**

features include trip/fall protection, shutdown time, emergency hard link tether and body harness keeping operator safe and comfortable throughout day.



The unit offers **QUICK SET-UP** and a **DYNAMIC RANGE OF OPERATION** with extreme rotation and 15-degree manual leveling capability in all directions. The boom delivers a 55-foot vertical reach, providing **UNMATCHED CUTTING ABILITY**.

Patented **ROTATING SAW HEAD** rotates 180°, providing the operator unmatched cut quality, accuracy and speed. A specially designed tooth guard adds an additionally level of operator safety.



JARRAFF.COM | 800-767-7112

Jarraff Industries LLC
1731 Gault Street, St. Peter, MN 56082

Mini-Jarraff SPECIFICATIONS

ELECTRICAL SYSTEM

- Power Requirements
- 12V - DC

BOOM, SAW HEAD, WINCH & PUSH BLADE

- Boom Construction - High-tensile, non-conductive fiberglass
- Saw Blade Diameter - 24 inches (610 mm)
- Saw Blade RPM - 2,990 RPM

OPERATIONAL CAPACITIES

- Maximum Cutting height - 55 feet (16.8 m)
- Rotation - 360° on turntable
- Rotation - 180° on boom
- Controls - wireless remote

PHYSICAL SPECIFICATIONS

- Traveling Length - 29 feet (8.84 m)

	4-Wheel Drive Model (Standard Tire Size - 31 x 15.5R15)
Undercarriage	Articulation
Weight	9,960 lbs (4,520 Kg) Full Wet Weight
Ground Pressure	15.7 PSI (1.08 Bar) w/15.50-15 Tires
Width (Outside Dimension)	Transport - 6 feet 2 inches (1.88 m) Operating - 10 feet 4 inches (3.15 m)
Carrier Length	15 feet 4 inches (4.67 m) - Variable as Wheels Extend
Height	10 feet (3.05 m)

Mini-Jarraff SPECIFICATIONS

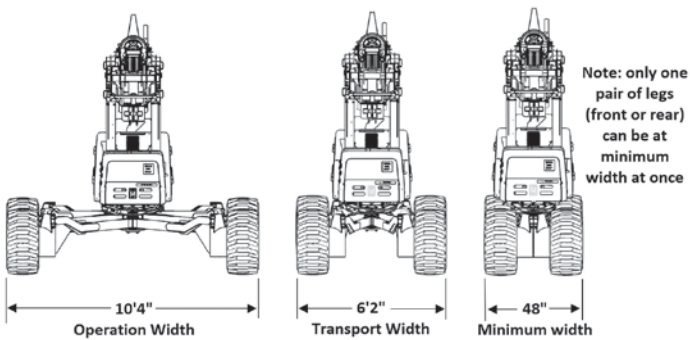

Note: only one pair of legs (front or rear) can be at minimum width at once

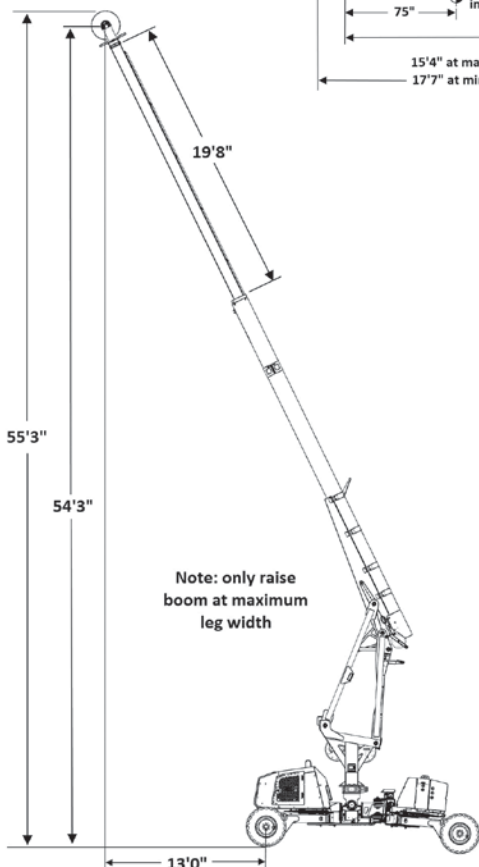
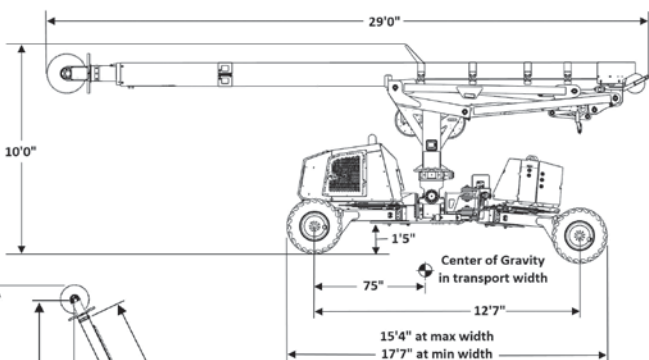

Note: only raise boom at maximum leg width



JARRAFF.COM | 800-767-7112

Jarraff Industries LLC
1731 Gault Street, St. Peter, MN 56082

PRODUCT SUPPORT

Quality parts and superior construction go into every piece of Jarraff equipment. Accessible machine design allows service work to be done quickly and easily, and a full maintenance schedule is included with each machine. Jarraff Industries equipment is field-proven in even the toughest



conditions and is backed by a knowledgeable service staff, ready to help you. Jarraff prides itself on OEM parts availability and next day air service from its 10,000 sq. ft. parts and service facility in St. Peter, MN to minimize your downtime. Jarraff's product support staff can walk you through repairs or arrange for a qualified field technician in your area. You can expect quality construction, service and support with everything you buy from Jarraff Industries.

Call Parts & Service: 800-767-7113

E-mail: parts@jarraff.com

AUTHORIZED SERVICE PROVIDERS

Authorized service providers from Jarraff Industries offer experienced mechanics and Jarraff OEM parts making it easier than ever to maintain your equipment.

Services Offered:

- Boom repair
- Part installation
- General maintenance
- Hydraulic service & more

Maximize productivity and extend the life of your Jarraff equipment.

Your Jarraff Product Support specialist will be happy to arrange for service at one of our sixty-two Jarraff Authorized Service Centers.



JARRAFF.COM | 800-767-7112

Jarraff Industries LLC
1731 Gault Street, St. Peter, MN 56082

FINANCING



Northern Atlantic Financial provides quick and easy financing for your Jarraff equipment needs. Specializing in the Tree & Landscape industry for over 20 years, no one knows the needs of arborists and landscapers better than Northern Atlantic.

Link to apply: <https://northernatlanticfinancial.com/online-credit-application/>

Contact Information:

JoAnn Cucciarre
joann@northernatlanticfinancial.com

www.northernatlanticfinancial.com

ADDRESS:

Northern Atlantic Financial Group
410 Turnberry Way
Souderton, PA 18964

PHONE: 800-710-4361

FAX: 800-711-0468



JARRAFF.COM | 800-767-7112

Jarraff Industries LLC
1731 Gault Street, St. Peter, MN 56082

FINANCING CREDIT APPLICATION



- SOLE PROP
- PARTNERSHIP
- CORPORATION
- LLC

Complete Legal Name _____ Email _____

Type of Business _____ Federal ID Number _____ Years in Business _____

Mailing/Business Address _____ County _____

Phone Number _____ Fax Number _____

Equipment Location _____ County _____

Phone Number _____ Contact _____

Insurance Agent _____ Agent's Phone Number _____

ARE YOU A US CITIZEN ____ YES ____ NO

PRINCIPAL / OFFICER / PARTNER	SOCIAL SECURITY	TITLE / % OWNED	HOME ADDRESS & TELEPHONE

BANK / MONEY MARKET ACCOUNTS	ACCOUNT #	TELEPHONE	OFFICER TO CONTACT
Business			
Business			
Business / Personal			

EQUIPMENT LOAN REFERENCE(S)	ACCOUNT # / TELEPHONE / CONTACT

EQUIPMENT TO BE PURCHASED

SUPPLIER:
Jarraff Industries Inc.
 1730 Gault Street - St. Peter, MN 56082
 TEL: 800-767-7112 FAX 507-934-8690

Type of Equipment _____
 NEW USED
 Cost of Equipment \$ _____

The undersigned individual, recognizing that his or her individual credit history may be a factor in the evaluation of the credit of the applicant, hereby consents to and authorizes the above named business credit provider and any assignee, lender or funding service that may be utilized to obtain and use a consumer credit report on the undersigned, now and from time to time, as may be needed in the credit evaluation and review process, and, if necessary, any collection actions to be taken on the account. The undersigned waives any right or claim they would otherwise have under the Fair Credit Report Act in the absence of this continuing consent.

I hereby authorize our banks, trades, and personal credit bureaus to release credit information to Northern Atlantic Financial, LLC. and/or its assignees.

X _____